

# MCP-501T/R / MCP-501TL/RL

Industrial Single Port Ethernet/PoE over coax transmitter / receiver with M12 Interface

MCP-501T/R



## Dimension

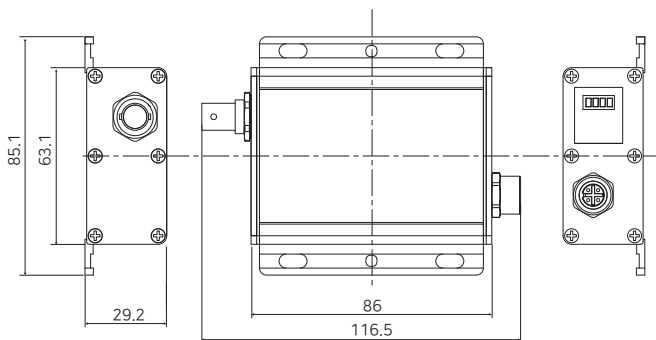

MCP-501TL/RL



## Dimension

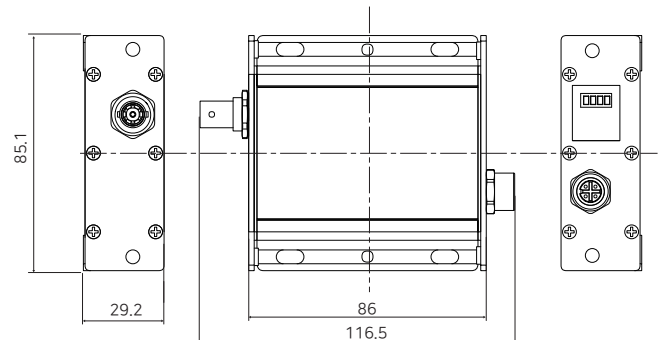

## Overview

MCP-501 is Ethernet / PoE over Coax converter that transmits the network data and PoE power over coaxial cable simultaneously. This device is cost-effective and time saving solution to migrate existing analog system to IP based system utilizing the existing coaxial and M12 cable infrastructure. Also, MCP-501 is an industrial product made in accordance with the IP65 standard of waterproofing and railway standards.

## Features

- Long range Ethernet over Coax communication following IEEE1901 Standard
- Network data and PoE over Coax (PoC, PoE)
- Max. 95Mbps Bandwidth (Max. 270Mbps between MCP-501)
- 10/100 Full Duplex
- M12 4 pin standard interface
- IEEE802.3 at/af standard PD/PSE
- Reliability based on railway certification standards and industrial environments
- IP65 water resistance

## Connection Diagram

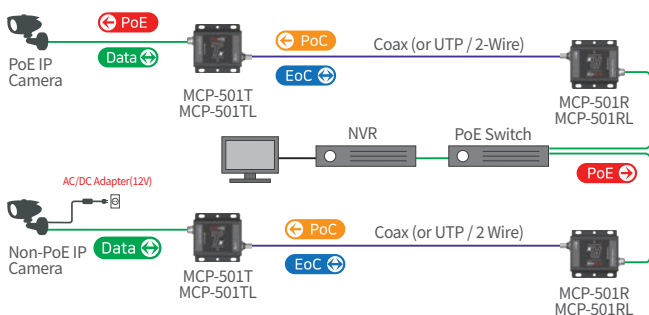

## Specification

Model		MCP-501T / TL	MCP-501R / RL
Interface	Coax	1 x 75Ω BNC (Female) - Ethernet over Coax (B-LinX)	
	M12	1 x M12 - 10/100 Base-T (Female, front lock)	
Transmission Rate		95Mbps Full Duplex / Ethernet (270Mbps between Intercoax devices / B-LinX)	
Transmission Distance	Ethernet	up to 1.2Km (RG-6)	
	PoE (PoC)	up to 1.2Km (7W camera / RG-6)	
LED Indication	Ethernet	1 x Data-Link (Yellow)	
	EoC	1 x Join-Link (Green)	
	Power	1 x Power On (Red)	
	PoE	1 x PoE Out (amber)	
Encryption		128-bit AES	
Power	Input	BNC (PoC / B-LinX)	M12 (PD / IEEE802.3at_CL4) [from PoE Switch or NVR]
	Output	M12 (PSE / IEEE802.3 at/af) [to PoE Camera]	BNC (PoC / B-LinX)
	Range	DC48V - 57V	
Mechanical	Dimension	86(L) x 85.1(W) x 29.2(H)mm Gasket (for IP Level), add option earth point (M4 screw)	
	Weight	MCP-501TL/RL : 169g	MCP-501T/R : 166g
Environment	Operating Temp	-25°C - 70°C	
	Storage Temp	-40°C - 85°C	
	Relative Humidity	10% ~ 90%	
	IP Level	IP65	
Compliance	Certification	FCC, CE, KC, RoHS	
	Protection	EN61000-4, EN50155	