

Quick Start Guide

ECP-2601T / ECP-2601R

Please read carefully the instruction manual before use. Contents of this manual are subject to change without prior notice for reasons such as functionality enhancements.

Rev.1.2

Package

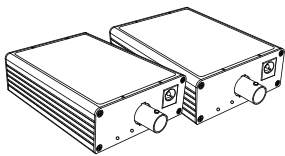

ECP-2601T (Transmitter)
ECP-2601R (Receiver)



Bracket



Quick Start
Guide

Hardware Overview

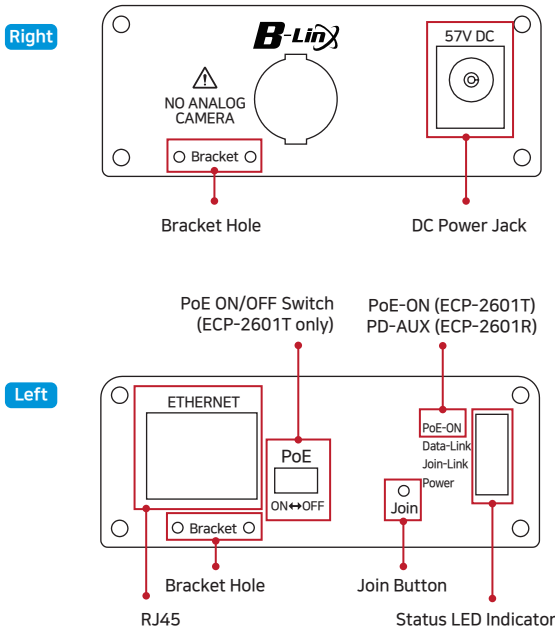

Overview

This device is a High-Speed, long distance Ethernet & PoE extender that makes possible to transmit the Ethernet signal up to 2.4Km and PoE up to 1.2Km via Coax (or UTP, 2-wire) cables in different situations.

It is cost-effective and time saving solution to migrate existing analog system to IP based system since this device supports easy installation utilizing the existing cable.

With long distance transmission feature, the device makes to overcome 100 meters distance limitation easily and reduces the construction cost significantly compared with fiber optic configuration.

Features

- Ethernet over Coax communication following IEEE1901 Standard
- Data + Power over Coax cable (or UTP, 2-Wire)
- Data distance up to 2.4Km
- PoE distance up to 1.2Km
- Max. 95Mbps Bandwidth (270Mbps between Intercoax 2 series models)
- 10/100 Full Duplex
- 128bit AES network encryption
- Supports Multi-connection (Daisy chain, Star, etc.)
- PoE, PoE+, Extra PoE (Max. 60W output)
- Supports UTP, Telephone (2 Pairs), 2-Wire cable communication (Using BTE Series)
- LED Indication (Data, Power, Link, PoE)
- Plug & Play
- Surge Protection
- Support PoE+ Input (25.5W) from PSE devices – ECP-2601R Only
- Slim design

Installation Guide

1. Set the IP address on the camera following the instruction manual of the camera.
 - ➔ If the camera IP is automatically assigned (DHCP, etc.), there is no need to set the camera IP separately.
2. Connect BNC of the coaxial cable to each **Transmitter/Receiver**.
3. Connect 57V DC power to **Transmitter/Receiver** first and then to AC outlet.
 - ➔ **Receiver** can be powered by PoE Switch Device (PoE+ PD Supported) but for safe working, it recommended to use 57V DC Power supply on **Receiver**. When using both PoE switch Device and power supply at the same time, power supply works preferentially.
 - ➔ In case of 7W camera, the device supports long distance PoE transmission up to 1,200m over RG6 coaxial cable. PoE transmission distance can be varied depending on cable type and Camera's power consumption(W).
4. When they are connected without any problem, Power / Join Link LED are on.
5. Adhere the brackets in the package to **Transmitter/Receiver** and then fix up the products.
6. Connect the UTP(LAN) cable between **Receiver** and NVR first and then between **Transmitter** and camera.
7. Turn on the PoE switch on **Transmitter** for PoE IP camera and if the camera is powered by a separate power source (not powered by PoE output feature of the **Transmitter**), turn off the PoE switch on **Transmitter**.
 - ➔ Both **Transmitter/Receiver** send data and power together via BNC connector. **Receiver** does not have PoE support so that it can send data only via RJ45.
8. Ping test is recommended to confirm the whole network after installation.
9. Check the video signal on the monitor.

LED Indicators

Indicator	Color	Function
PoE-ON (Tx)	Red	ON : PoE Switch On (PoE Output) OFF : PoE Switch Off
PD-AUX (Rx)	Red	ON : PoE Input or Powered by Transmitter OFF : Powered by adapter
Data-Link	Yellow	Blinking : Ethernet Data Act
Join-Link	Green	ECP-Product Link
Power	Orange	57V DC Link

Applications

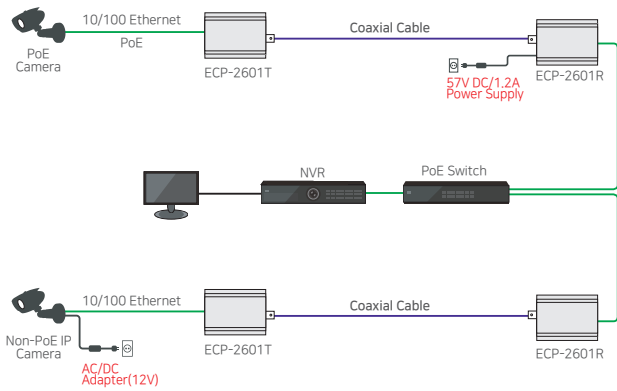

How to change the communication password (Coax/UTP/2-Wire)

All Intercoax EoC converters have the same password as factory defaults setting value and can be used immediately when connecting to the product (Plug & Play mode).

However, if a number of products are mixed in the same area or the signal transmission line is in poor condition, the communication passwords for each equipment (or group) can be set differently to prevent cross-talk between the lines.

1. Needed items for Joining

EoC Converters / Power supply / Short Cable (Coax, UTP, 2-Wire) / Paper clip

2. Product configuration

- Connect EoC Converters with Coax cable (or UTP, 2-Wire) and power to the one of the converters up with power supply.
- Check if the Power LED on both devices is ON.

3. Remove the existing password (Unjoining)

This process removes passwords that are entered as factory defaults.

- Press the Join button on one of the connected products using a paper clip until the Power LED turns off and on (Approximately 15 seconds)
- Remove the existing password by pressing the Join button on the opposite product in the same way as above.
- Join LED will be turned off if the password on the devices is removed correctly.

4. Create New Password (Joining)

New password for communication between connected devices is created and this will block the communication with other devices (or group) which have a different password.

- Press the Join button for 2 seconds on one of the connected product using a paper clip and the Join LED of the device will flicker at a constant speed. (Stand-by mode)
- Press the Join button for 2 seconds on the opposite device in the same way as above. And then, the Join LED of the device flickers at a constant speed and both devices restart at the same time.
- Then the Join-Link lights up and communications are resumed between the products

5. When adding new products in 1:N configuration to a group that has already been joined. (Group Joining)

- Connect new device to the group which is already joined. (using T-BNC or Y-UTP coupler, Terminal block)
- Remove the password of the new device in the same way as step '3-a'.
- Press Join button on the one of the device of the existing group for 2 seconds and Join LED flickers at a constant speed.
- Press Join button on the new device for 2 seconds and new device restarts
- Join-Link lights up and communications are resumed between the products.

Specification

Model		ECP-2601T	ECP-2601R
Interface	Coax	1 x 75Ω BNC (Female) - Ethernet over Coax	
	Ethernet	1 x RJ45 - 10/100 Base-T with Auto-detect MDIX	
Transmission Rate		95Mbps Full Duplex (270Mbps between Intercoax devices)	
Transmission Distance	Data	up to 2.4Km(RG-6)	
	PoE (PoC)	up to 1.2Km (RG-6 / 7W camera)	
LED Indication	Ethernet	1 x Data-Link (Yellow)	
	EoC	1 x Join-Link (Green)	
	Power	1 x Power On(Amber)	
	PoE	1 x PoE Out (Red)	
Encryption		128-bit AES	
Power	Input	ECP-2601R or DC48V~57V	PoE Switch/NVR (Max. 25W) or DC 48V~57V(Max. 70W)
	PoE Output	IEEE802.3af (PoE), IEEE802.3at (PoE+), Extra PoE up to 60W with 57V Power Adaptor	PoE Not Supported PoC Only
Mechanical	Dimension	82.4(L) x 61.6(W) x 24(H)mm	
	Weight	77g	
Environment	Operating Temp	-20 ~ 60°C	
	Storage Temp	-30 ~ 80°C	
	Relative Humidity	10% ~ 90%	
Compliance	Certification	FCC, CE, KC, RoHS	
	Surge Protection	IEC 61000-4-5 4kV(1.2 / 50us), 2kA(8 / 20us)	
Optional Accessories		57VDC / 1.2A External Power Supply	

Caution

- Please install the device following the installation guide.
- Do not touch the device and cable with wet hands.
- Keep away from moisture and shock.
- Do not install near any heat sources such as radiators, heat registers, stoves or other apparatus that produce heat.
- Indoor use only.
- Do not use for other purposes.
- Do not disassemble or modify this device.
- Do not put any sticker or paint on it.
- If this device is defective or malfunctioning, please unplug the power adapter immediately and contact dealer or service center.
- Please use the rated power supply for the product.
- Connect DC power to this device first and then to AC outlet.

Warranty

- This device has passed the quality control and product inspection.
- Please install and use according to the installation guide.
- The warranty period for this product is 24 months from the date of purchase.
- If this device is defective or malfunctioning, please unplug the power adapter immediately and contact dealer or service center.
- Any damages or breakage from user's abuse, accident, modification or natural disasters will not be covered manufacturer's warranty.



Please visit below website for more detailed information.

Web: <http://www.intercoax.com> Tel: +82. 31. 365. 3133~4

Intercoax Co., Ltd.

E-mail: info@intercoax.com Fax: +82. 31. 365. 3135

This device complies with part 15 of the fcc rules. Operation is subject to the following two conditions :

- (1) This device may not cause harmful interference, and
- (2) This device must accept any interference received including interference that may cause undesired operation